

Yanmar type 6BY2-260Z

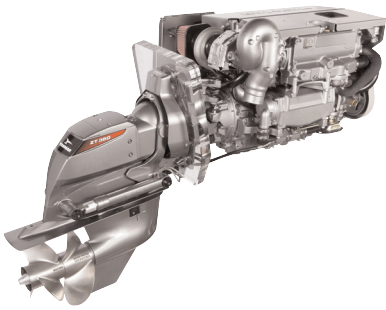

Configuration	In line, 4-stroke cycle, water cooled diesel engine
Maximum output at crankshaft *	191 kW (260 mhp) / 4000 rpm
Continuous rating output at crankshaft	147 kW (198 mhp) 3600 rpm
Displacement	2.993 L (183 cu in)
Bore x stroke	84 mm x 90 mm (3.31 in x 3.54 in)
Cylinders	6, Common Rail with vertical injectors
Combustion system	Direct injection
Aspiration	Wastegated, turbocharged with intercooler
Starting system	Electric starting 12 V - 2 kW
Alternator	12 V - 150 A
Cooling system	Fresh water cooling with heat exchanger, and sea water cooled charge air cooler
Lubrication system	Totally enclosed, forced lubricating system with pump
Can Bus	According to NMEA 2000 protocol
Direction of rotation (crankshaft)	Counter clockwise viewed from Flywheel side
Dry weight without sterndrive	315 kg (694 lbs)
Environmental	EU RCD, US EPA Tier 2, BSO II & EMC
Engine mounting	Rubber type antivibration mounts

NOTE: Fuel condition: Density at 15°C = 0.84 g/cm³; 1kW = 1.3596 mhp = 1.3410 HP

* Fuel temperature 40°C at the inlet of the fuel injection pump (ISO 8665 : 2006)

Dimensions (For detailed line-drawings, please refer to our web-site: www.yanmarmarine.com or contact your supplier)

Front view

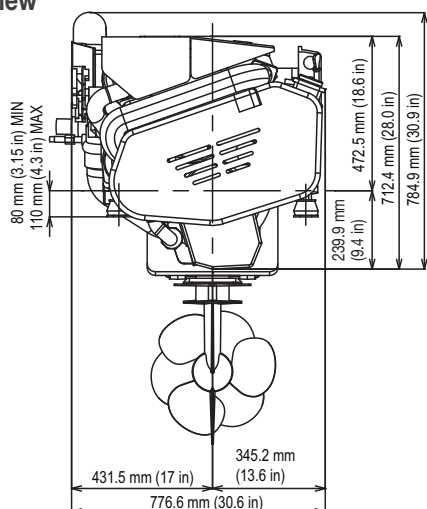

Right side view

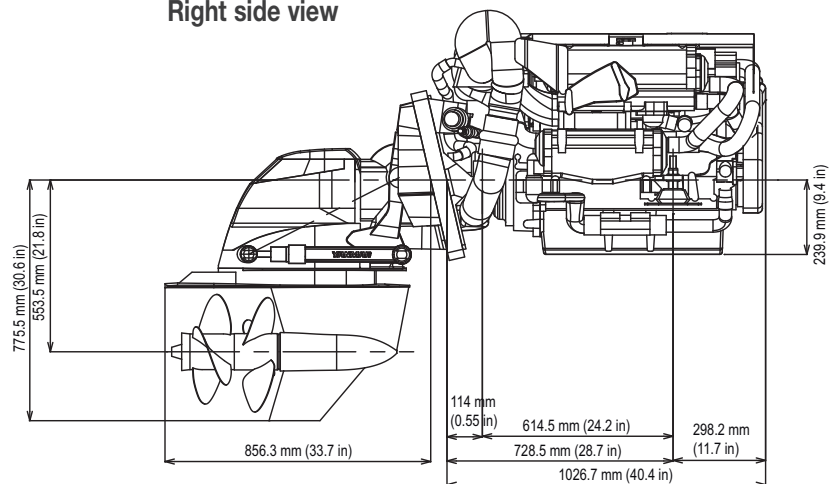

6BY2-260Z with Yanmar Sterndrive ZT350

Performance Curves (Output is according ISO 8665)

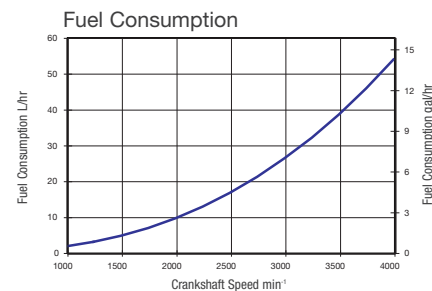
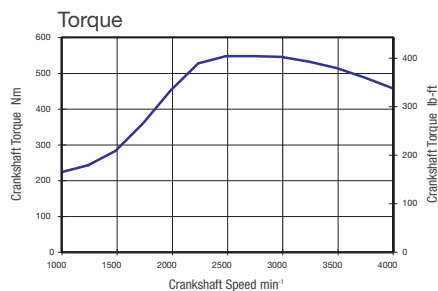
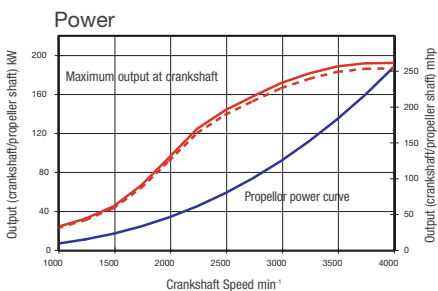

Yanmar sterndrive set Engine

Model	Yanmar Sterndrive ZT350			
Type	ZT350			
Dry weight with propellers	112 kg (247 lbs)			
Reduction ratio (fwd/asn)	1.65/1.65	1.78/1.78	1.97/1.97	2.18/2.18
Propeller speed (fwd/asn)	2424/2424	2247/2247	2030/2030	1835/1835
Direction of rotation (propeller shaft - fwd)	Clockwise & counter clockwise viewed from flywheel side			
Dry weight engine with sterndrive	427 kg (941 lbs)			

1, Inner and outer transom surface must be parallel within 3mm in area covered by transom plates and remain within transom thickness limits.

2, Area covered by gimbal housing assembly must be flat to within 1.6mm.

3, Area covered by inner transom plate must be flat to within 3.2mm

4, Transom angle: 13° to 16°

5, Also available with: BravoX-1 and BravoX-2. Contact your local supplier for available configurations

Instrument Panels

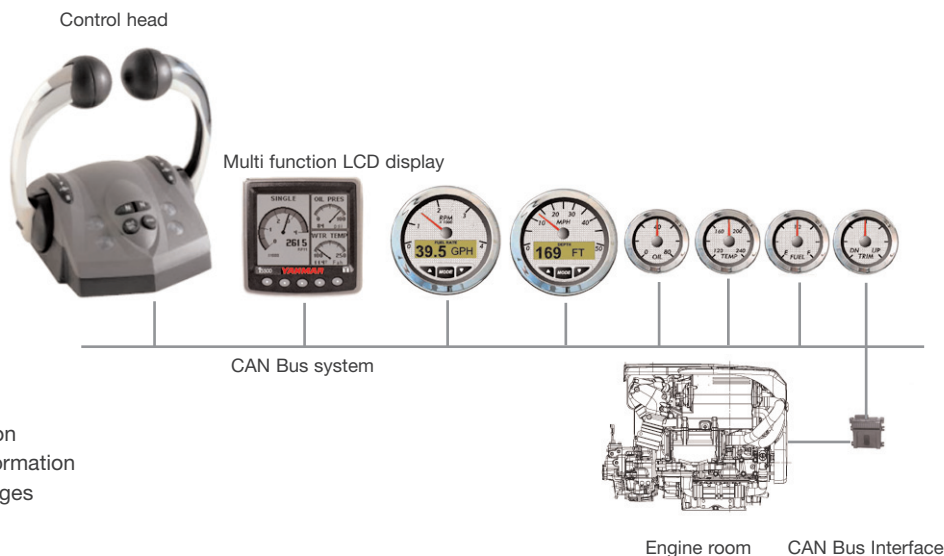

Multi function LCD display:

- engine information
- maintenance information
- diagnosis messages

Engine Accessories

Standard Engine Package System

- Alternator 12V - 150A single pole
- Protection cover for engine transmission
- High riser mixing elbow
- Flexible Mounts
- Glow plug controller and related parts

Optional Engine Package System

- Exhaust side dipstick
- Electrical Gearshift

Electronic Control System

Standard Electronic Control

- Electronic Control Head
- LCD display

Optional Electronic Control

- Various engine Monitoring gauges
- Various engine Control heads