



MARINER 1600 MARINER 1601

15.3 kW **18.4 kW**
50 Hz **60 Hz**

Control Panel

The gen-set control panel was designed to include, in one single panel, the switches, control devices and the protection devices. The components are the following :

- Engine cut-off module for automatic stop of engine in case of high water temperature, low oil pressure, high alternator temperature.
- Hour-meter.
- Start-stop button.
- Breaker for protection against of overload or short circuit.
- Thermal switch for D.C. electric circuit.

Engine

- Easy access in case of maintenance to the feeding system and lubrication, of the sea/water pump and the air filter.
- Safety stop in case of low oil pressure.
- Safety stop in case high water/exhaust gas temperature.
- Oil and fuel filters of easy access.

Alternator

- Synchronous, 4 poles, brush less self-excited, electronic voltage regulator (AVR).
- Rotor and stator coated with epoxy resin against external agents.
- Rotor dynamically balanced.
- Insulation class H.

Soundproof cabin

A new project engineering design with a new very light structure of painted marine aluminum plate, type 5754 with high resistance to external agents.

Good accessibility inside canopy makes the interventions of maintenance easier also with generator installed in narrow sites.

Engine	50 Hz	60Hz
Model	Yanmar 4TNV88	
Type	Diesel 4 stroke	
Cylinders (nr.)	4	
Cylinder block material	Cast iron	
Bore (mm. - in.)	88 - 3.46	
Stroke (mm.- in.)	90 - 3.5	
Displacement (cc. - CID)	2190 - 133.6	
Power (hp)	24.5	29.4
RPM	1500	1800
Compression ratio	19.1:1	
Combustion system	Direct injection	
Engine head material	Cast iron	
Speed governor	Centrifugal mechanical	
Lubrication system	Forced	
Oil sump capacity with filter(l -gl)	7.4 - 2.85	
Engine stop system	Stop solenoid	
Fuel pump	Electric	
Fuel pump discharge (cm. - ft)	70 - 2.29	
Fuel consumption (l/h - gl/h)	5.6 - 1.23	6.7 1.47
Air intake (l/min. - gl/min.)	1500 - 328	1800 - 394
Starting battery (Ah-V)	80 - 12	
Battery charger (Ah-V)	40 - 12	
Starter (kW-V)	1.2 - 12	
Max. inclination	30°	
Water pump flow (l/min. - gl/min.)	25 - 5.4	28 - 6.1

Alternator	50 Hz	60Hz
Type	Synchronous, 4-poles, brush less self-excited	
Voltage regulation	Electronic	
Cooling	Air	
Voltage (V)	115 - 230	120 - 240
Frequency (Hz)	50	60
Amps	133 - 66.5	153.3 - 76.6
Max. power (kW)	15.3	18.4
Continuous power (kW)	13.9	16.7
Power factor (cos ø)	1	
Insulating class	H	
Voltage stability	±2%	
Frequency stability	±5%	

Cooling system

The cooling of the engine is based on a closed inner flow of coolant. The system is based on a cupronickel heat exchanger seawater/coolant type, where the thermal exchange occurs between coolant and seawater. Two separate pumps contribute to the flow of the coolant and the sea water.

	50 Hz	60Hz
Dimension (Length x Width x Height.)	1135x631x694mm - 44.5x25x27 (in.) (with soundproof box)	
Weight	400 Kg. - 888 (lb) (with soundproof box)	
Noise Level	52 dB _A at 7mt (23 ft)	

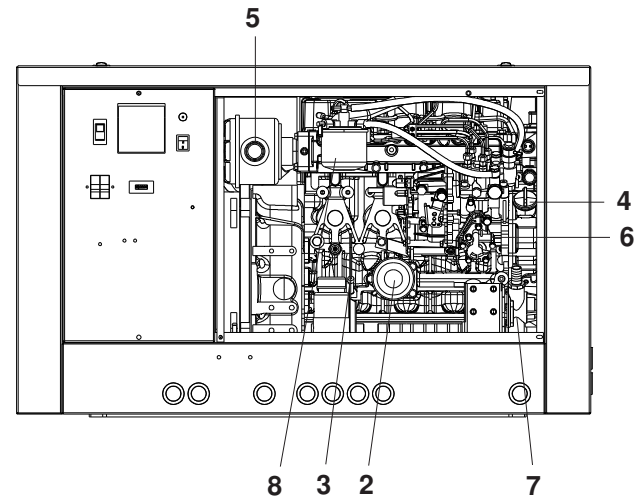
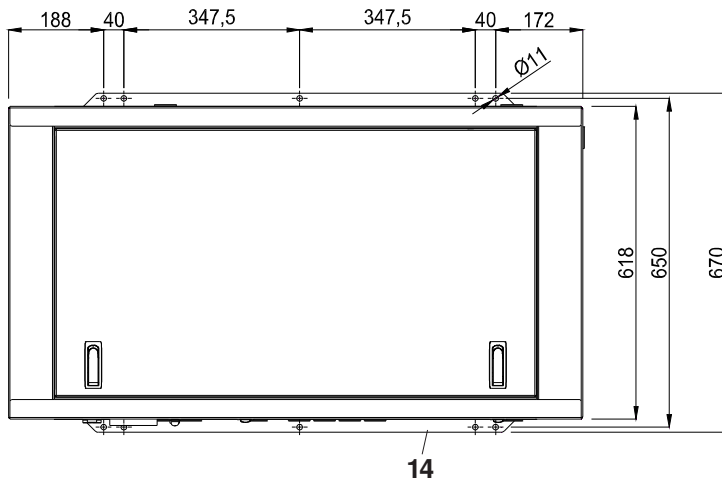
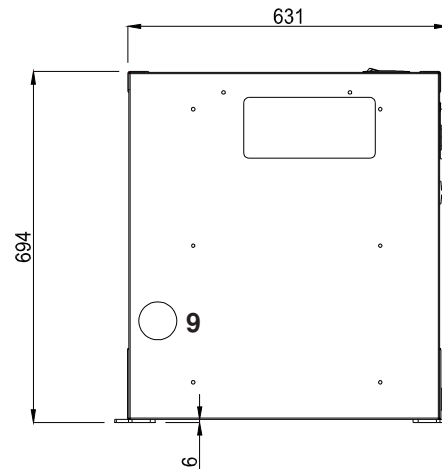
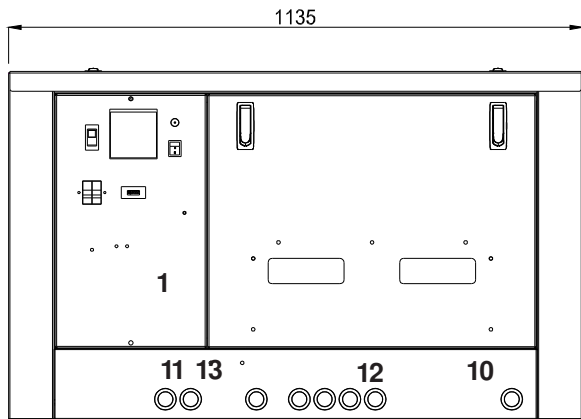

- 1 - Control panel
- 2 - Engine oil filter cartridge
- 3 - Oil dipstick
- 4 - Engine oil cap
- 5 - Air filter
- 6 - Closed circuit water pump
- 7 - Seawater pump

- 8 - Fuel filter
- 9 - Seawater exhaust connection (ø 50mm)
- 10 - Seawater inlet (ø 16mm)
- 11 - Battery connection
- 12 - Fuel tank connection (ø 8mm)
- 13 - Electric cables outlet
- 14 - Fixing stirrups

FITTINGS

EXHAUST COMPONENTS KIT

SIPHON BREAK

WATER-GAS SEPARATOR KIT

STARTING REMOTE CONTROL PANEL WITH INSTRUMENTS

*This drawing is only a reference and is not indicatly for the installation. For more information, you may contact your local dealer or **mase** generators S.p.A..*

mase generators S.p.A. reserves the right to change the design or specifications without notice and without any obligations or liability whatsoever. For more information, you may contact your local **mase** dealer.

Dealer: