

MARINE DIESEL ENGINES

6KH(M)-STE
338~394kW(460~536hp)

YANMAR

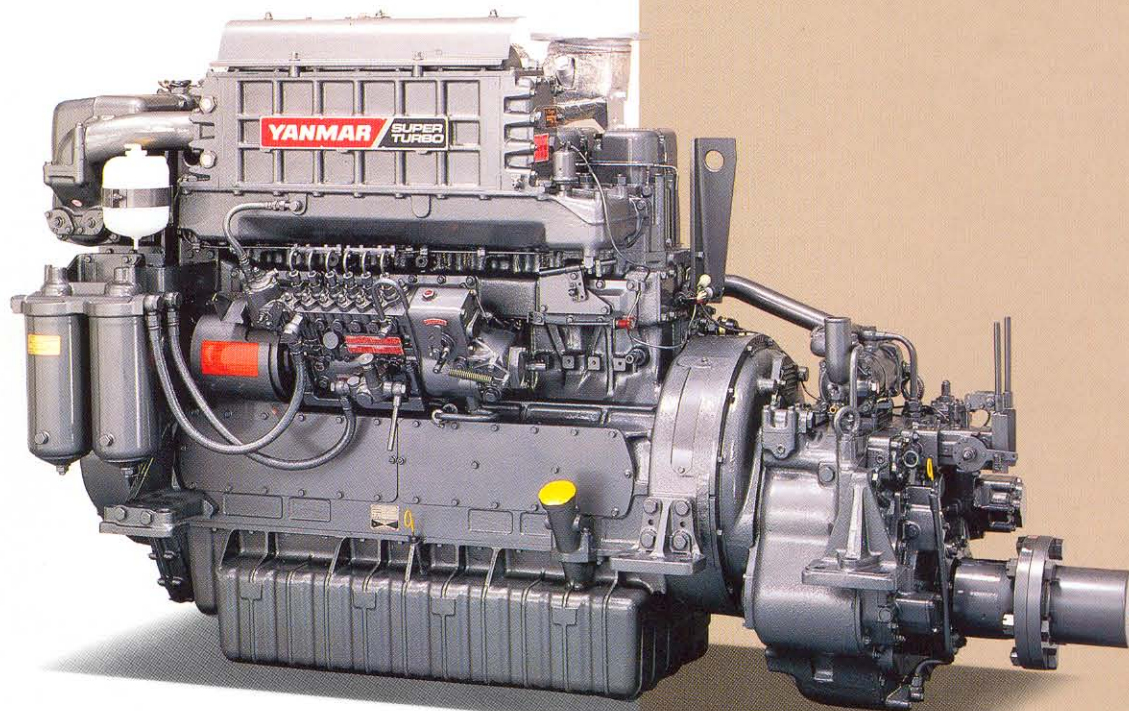

Photograph may show optional equipment.

The Right Power & Pace, at t

Yanmar puts modern technology to work for the fisherman and workboat operator with this latest turbo-charged diesel. It offers the very best of modern systems.

And they're all in a more compact package.

Look at these advanced features to see how much better the new 6KH-STE weighs up.

With a 2000rpm rating this sturdy engine has the pep to outperform slower diesels. Four valves on each of its six cylinders give smooth air flow. Direct injection adds power and economy to the combustion system, coming from one of the latest ultra-high pressure fuel pumps.

The 6KH-STE also works to protect your environment.

A boost compensator reduces black smoke at acceleration while regular emissions are minimized by the ultra-high injection pressure and efficient, turbo-charged combustion process.

The robust performance of the 6KH-STE is supported by a stiff engine block designed to reduce vibrations and suppress running noises.

Power is delivered efficiently to the prop by a Yanmar marine gear — a high performance unit ideally matched to the engine.

All six cylinder heads are independent, meaning faster checks, easier maintenance. A big inspection hatch opens up the block for on-board servicing.

PERFORMANCE CURVES

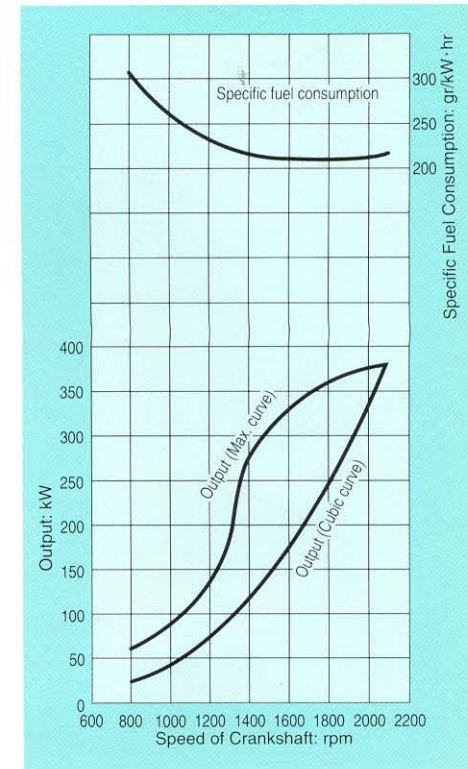

ENGINE SPECIFICATIONS

Model		6KH-STE (with marine gear)	6KHM-STE (without marine gear)
Type		4-cycle, vertical, turbo-charged, diesel engine	
Number of cylinders		6 in-line	
Bore × stroke		mm(in.) 135 × 160 (5.31 × 6.30)	
Displacement		ℓ (cu.in.) 13.74(838.5)	
Output	Rated	338(460)/2000	349(475)/2000
	Max.	382(520)/2100	394(536)/2100
Fuel consumption		217	211
Direction of rotation (crankshaft)		Counterclockwise viewed from stern	
Combustion system		Direct injection	
Cooling system		Fresh water cooling with sea water & fresh water pumps	
Lubricating system		Forced lubrication with gear pump	
Starting system		Electric starting motor (DC 24V)	
Dry weight		1840(4056)[with YX-151]	1450(3197)

MARINE GEAR SPECIFICATIONS

Model		YX-151				YX-150L		
Type		Hydraulic multi-disc clutch, wet type						
Reduction ratio (forward)		1.72	2.08	2.55	3.03	3.55	4.03	4.59
Propeller shaft speed (at rated)		rpm 1162	962	784	660	563	496	436
Direction of rotation (prop. shaft)		Counterclockwise viewed from stern						
Dry weight		kg(lbs) 390(860)				480(1058)		

Get the Right Price.

DIMENSIONS

Unit:mm

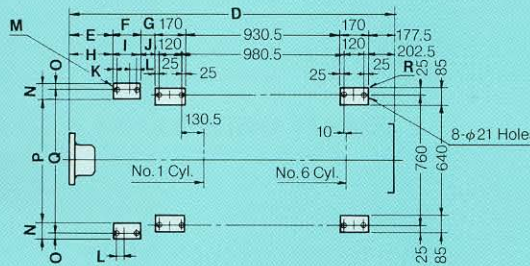
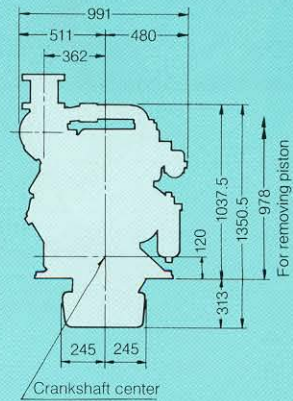
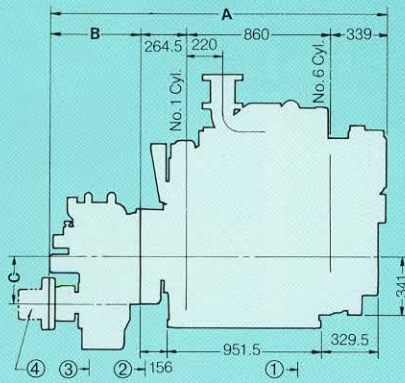
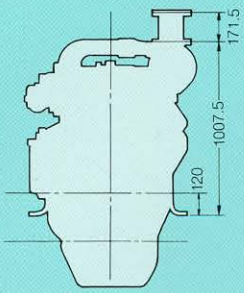

View from top

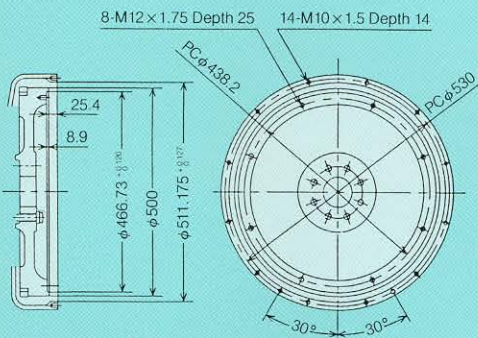

Detail of flywheel & flywheel housing
Model: 6KHM-STE

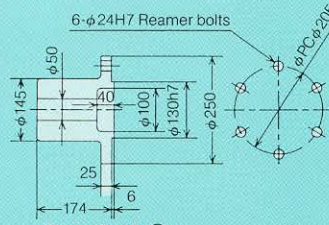

Detail of ④
Model: 6KH-STE x YX-151

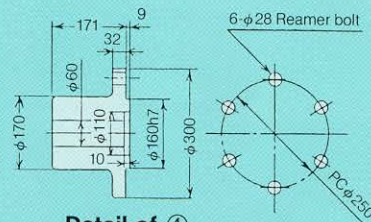

Detail of ④
Model: 6KH-STE x YX150L

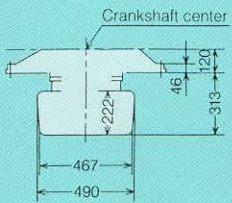

Section ①

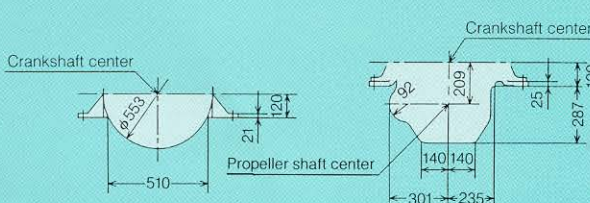

Section ②

Model: YX151

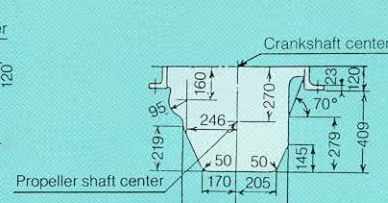

Section ③

Model: YX150L

Model	A	B	C	D	E	F	G	H	I	J	K	L	M	N	O	P	Q	R
6KHM-STE	1474.5	—	—	1448	—	—	—	—	—	—	—	—	—	—	—	—	—	—
6KH-STE x YX151	2031.5	568	209	2005	177	174	206	204	120	258	27	—	4-φ22 Holes	92	27	630	760	6-M16 Jack bolts
6KH-STE x YX150L	1983.5	520	270	1957	249	174	86	276	120	138	27	45	4-φ22 Holes	92	28	702	830	6-M16 Jack bolts

ACCESSORIES

Remarks: ● Standard △ Optional

Item	Name of accessories	Q'ty	6KH-STE
Installation	Installation plate for wooden boat	2	△
	Adjusting shim for engine	1 set	△
	Adjusting shim for marine gear	1 set	△
	Installation bolt kit	1 set	△
	Jack bolt	1 set	△
	Chock liner, bolt & nut for steel boat	1 set	△
	B-type V-pully for front P.T.O	1 set	△
Air	Exhaust gas pipe	1	△
	Breather hose with fittings	1 set	●
	Exh. flexible joint (T/C out)	1	●
	Exh. thermometer (T/C inlet)	2	△
	Intake air filter	1	●
	Exh. gas silencer	1	△
Fuel oil	Engine room ventilator	1 set	△
	Drain separator	1	●
	Duplex type fuel filter (mounted on eng.)	1	△
	Fuel sedimentary filter	1	△
Lubrication oil	Fuel oil pipe	1	△
	Evacuation hand pump	1	●
Cooling system	Duplex type oil filter (mounted on eng.)	1	△
	Kingston cock	1	△
	Kingston valve	1	△
	Raw water filter (simplex)	1	△
	Bilge pump (electric type)	1	△
	Fresh water sub-tank	1	●

Item	Name of accessories	Q'ty	6KH-STE
Cooling system	Raw water pipe	1	△
Electric device	Battery switch	1	△
	Charging Alternator	1	●
	Starting motor (1-pole type)	1 set	●
	Starting motor w/harness (2-pole type)	1 set	△
	Battery	1 set	△
	Remote control	Control head (2-handle type)	1
Control head (1-handle type)		1	△
Push-pull cable (- 10m)		2	△
Push-pull cable (12m - 20m)		2	△
Wireharness (4m x Q'ty)			△
Instrument panel for wheel house (D-type)		1	●
Dual type instrument panel (C-type)		1	△
Connection wireharness for dual panel		1	
Engine panel (mounted on eng.)		1	△
Emergency stop push button with solenoid		1	△
Others	Over speed relay	1	△
	Half coupling (rough bore type)	1	●
	Standard spare parts	1	●
	Standard tool kit	1	●
	Operation manual	1	●
	Parts book for engine	1	△
	Service manual	1	△

INSTRUMENT PANEL CONTAINS FOLLOWING ITEMS

Unit: mm (in.)

Detail of instrument panel C-type

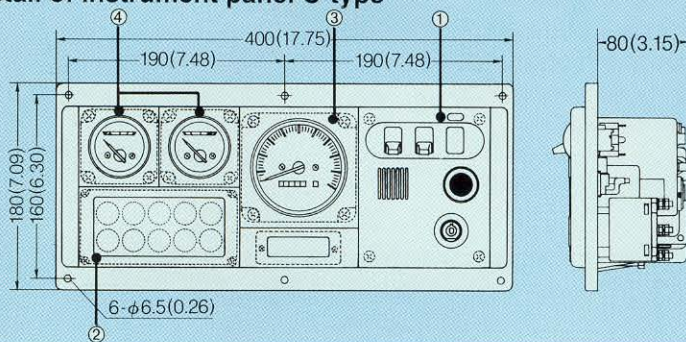

- ① **Switch unit**
- Key switch
 - Alarm buzzer
 - Alarm buzzer stop switch
 - Illumination switch
- ② **Alarm lamp unit with Alarm monitor device**
- Battery not charging
 - C.W. high temp.
 - L.O. low pressure
 - Clutch oil pressure
 - L.O. filter clogged
 - C.W. level

- ③ **Tachometer unit**
- Tachometer with hour meter
- ④ **Sub meter unit**
- L.O. pressure meter
 - C.W. temp. meter

Detail of instrument panel D-type

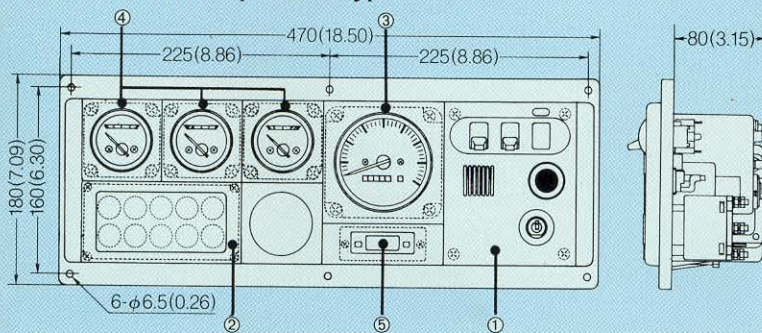

- ① **Switch unit**
- Key switch
 - Alarm buzzer
 - Alarm buzzer stop switch
 - Illumination switch
- ② **Alarm lamp unit with Alarm monitor device**
- Battery not charging
 - C.W. high temp.
 - L.O. low pressure
 - Clutch oil pressure
 - L.O. filter clogged
 - C.W. level

- ③ **Tachometer unit**
- Tachometer with hour meter
- ④ **Sub meter unit**
- L.O. pressure meter
 - C.W. temp. meter
 - Boost meter (Turbo)
- ⑤ **Clock unit**
- Clock

Note: All data subject to alteration without notice.

YANMAR DIESEL ENGINE CO., LTD.

OVERSEAS OPERATIONS DIVISION

1-1, 2-chome, Yaesu, Chuo-ku, Tokyo 104, Japan
 Telex: 0222-4733 Telephone: 03-3275-4933
 Facsimile: 03-3275-4967 Cable: YANMAR TOKYO

