

“Please don’t drown me”

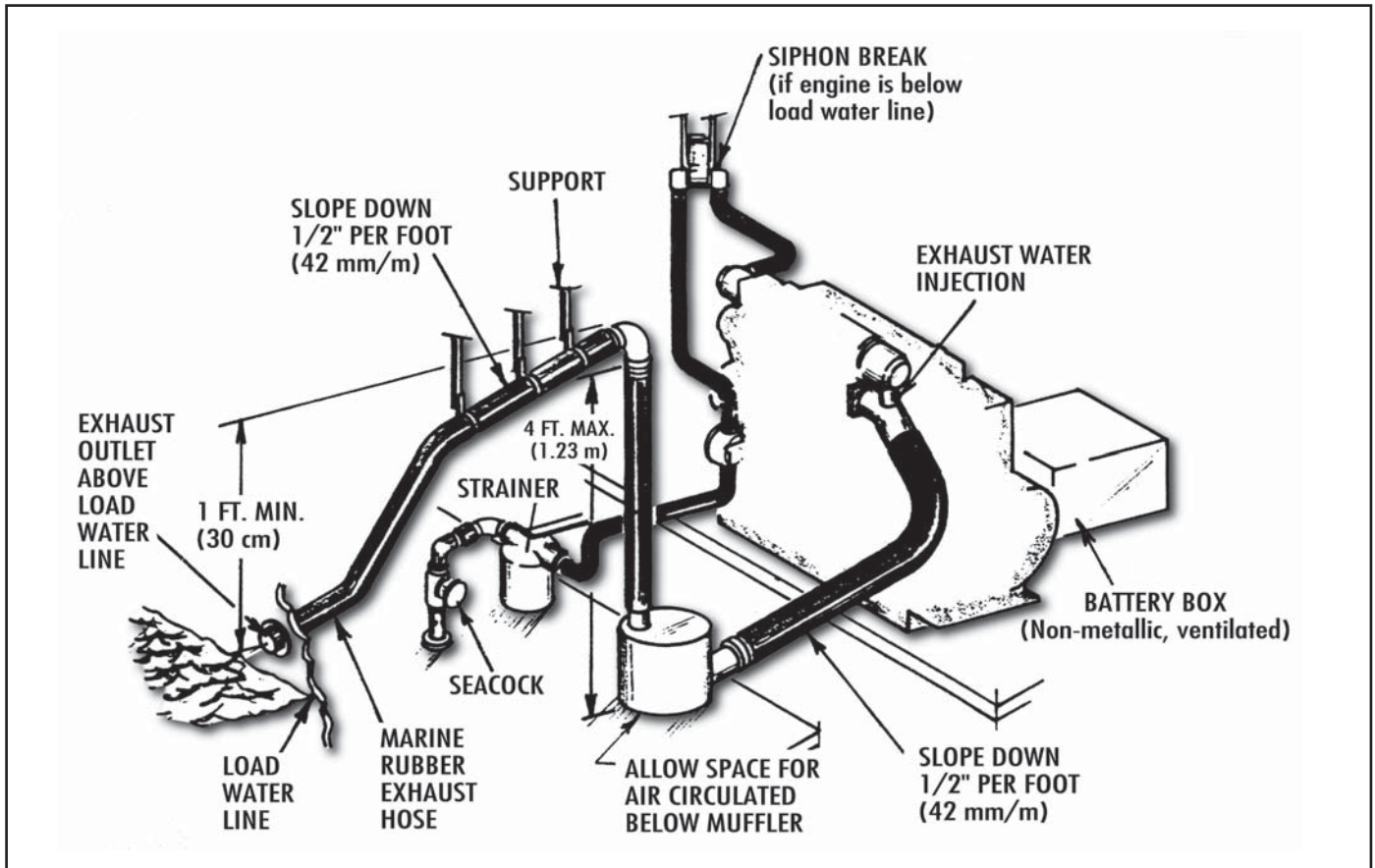

Figure 1. Properly installed wet exhaust system.

Part Number 00-30009

Important Exhaust System Installation Information

This generator set is equipped with a wet exhaust system. **Improper installation can fill up the engine with water and cause severe engine damage which will not be covered by your warranty.**

Please read this flyer, then, for more information, see the Northern lights Installation Manual (publication number IM-1000).

If you have any installation questions please see your dealer or call the Factory Service Information Department at (206) 789-3880.



“Please Don't Drown Me”

Before you install your new generator, you must decide whether a dry or wet exhaust system is best suited to your boat. In a dry system, exhaust gases are simply vented to the outside through an insulated pipe. A wet system is more complicated, because exhaust gases are cooled by water before they leave the boat. Plumbing a wet exhaust system incorrectly is a major cause of generator set failure (see Fig. 1).



If you are a boatyard mechanic, the following tips will help to ensure the safe installation and operation of the wet exhaust system. If you are a boat owner, they will help you determine if the job was done right.

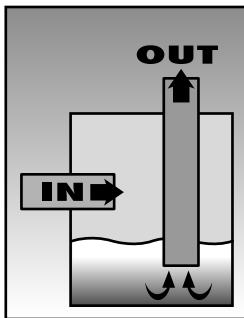

Fig. 2: How a water-lift muffler (top) works.

Remember, this pamphlet is *not* a substitute for the more complete instructions in the IM1000 Installation Manual available from a Northern Lights dealer.

1. Never use a scoop type water inlet fitting on the outside of your hull!

These scoops can force water past the impeller in your raw water pump, then fill the muffler and back water up into the exhaust manifold and the cylinders.

2. Always locate the exhaust outlet above the boat's loaded waterline. On sailboats, we recommend an exhaust thru-hull in the transom, so it stays above the waterline, no matter what angle of heel.

3. Plumb a loop between the muffler and the exhaust outlet. Loop must be least a foot above the loaded waterline.

4. Maintain a slope of 1/2" per foot in your exhaust lines from the manifold to the muffler (Fig. 1-A) and from exhaust loop to outlet (Fig. 1-B) to ensure proper drainage.

5. Make sure that there is no low spot or belly in the exhaust hose where water can be trapped and flow back into the engine when the boat pitches and rolls.

6. If the point where the cooling water is injected into the exhaust is at least one foot above the loaded waterline, your installation should follow Fig. 5.

7. You will need a siphon break if your generator sits so low that the point where the cooling water is injected into the exhaust is less than a foot above the waterline. See Fig. 6.



Thanks to a natural phenomenon known as the siphon effect, under certain conditions, water can flow uphill (see Fig. 3). Atmospheric pressure will force water up a tube from which all the air has been evacuated.

After a marine set is shut down, water can siphon past the raw water pump unless a vented loop is placed between the pump and the engine's heat exchanger.

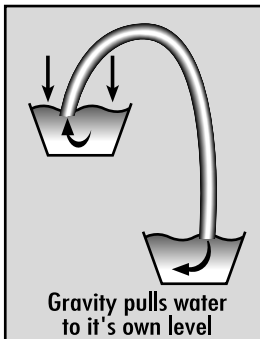

Fig. 3: Siphon Effect.

The top of the loop must be at least one foot above the water line. A siphon break is installed at this point. The siphon break is a small air valve that closes when the pump is working and opens when the pump stops. This forms an air bubble in the loop and makes it impossible for the siphon effect to take place.

Important! A siphon break requires periodic maintenance, check it every time you change the oil to make sure that it is working (see Fig. 4).

8. Four feet is the maximum vertical lift between the waterlift muffler and the top of the exhaust loop. Otherwise, the muffler will not be able to evacuate the water fast enough to keep it from backing up into the engine. If your generator sits so low that the muffler will have to be raised above the exhaust manifold to comply with the four foot maximum vertical lift rule, plumb your system according to Fig. 7.

Remember, you are only allowed a maximum of four feet, you can't plumb an exhaust in a series of four foot steps.

9. Don't over crank your engine.

When you over crank an engine that doesn't start, (when bleeding the fuel system for example), there is no exhaust pressure to empty the muffler. Water fills the muffler and can then back up the exhaust hose into the engine.

If you must crank your engine for more than one minute at a time, close the seacock and remove the impeller from your raw water pump until the engine can be started. Stop the engine immediately, replace the impeller. Open the seacock.

10. Questions? Call your dealer or factory branch in your area.

It takes only two teaspoonfuls of water to wreck your engine, but one simple phone call can save yourself a boatload of grief and ensure years of safe operation.

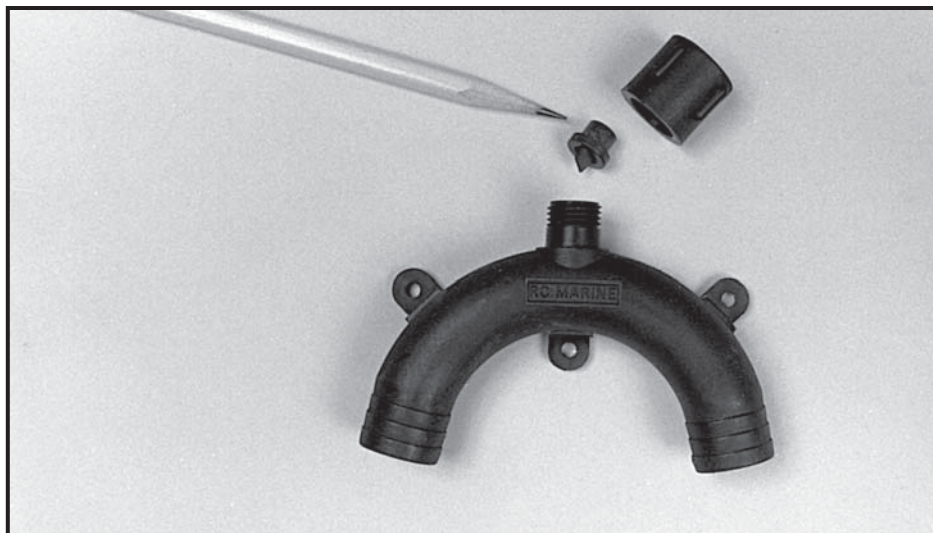
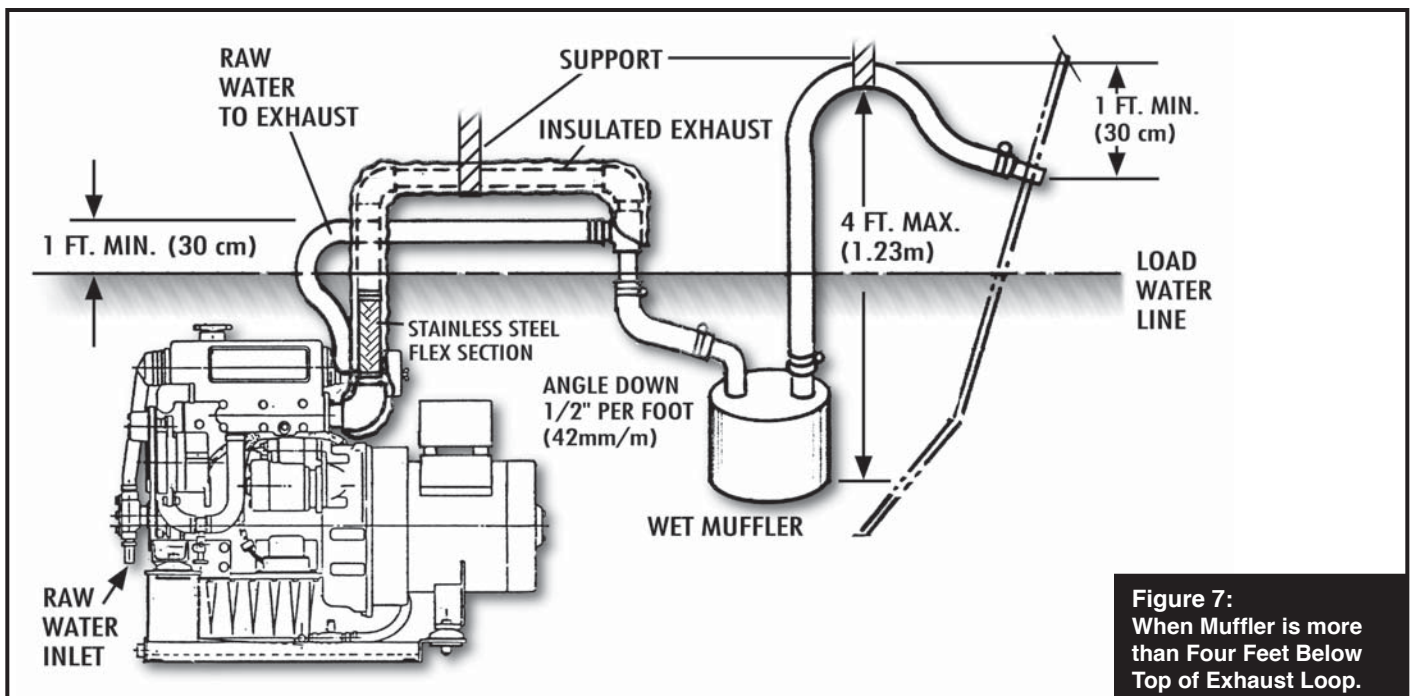
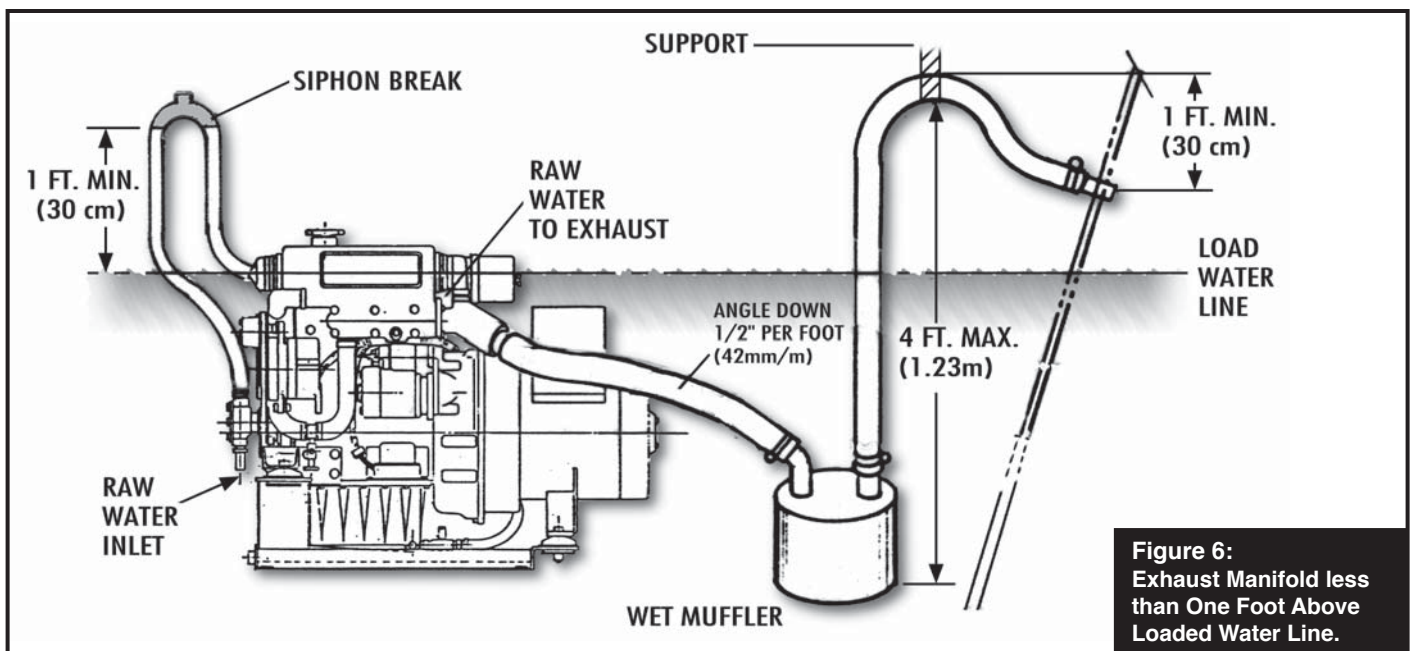
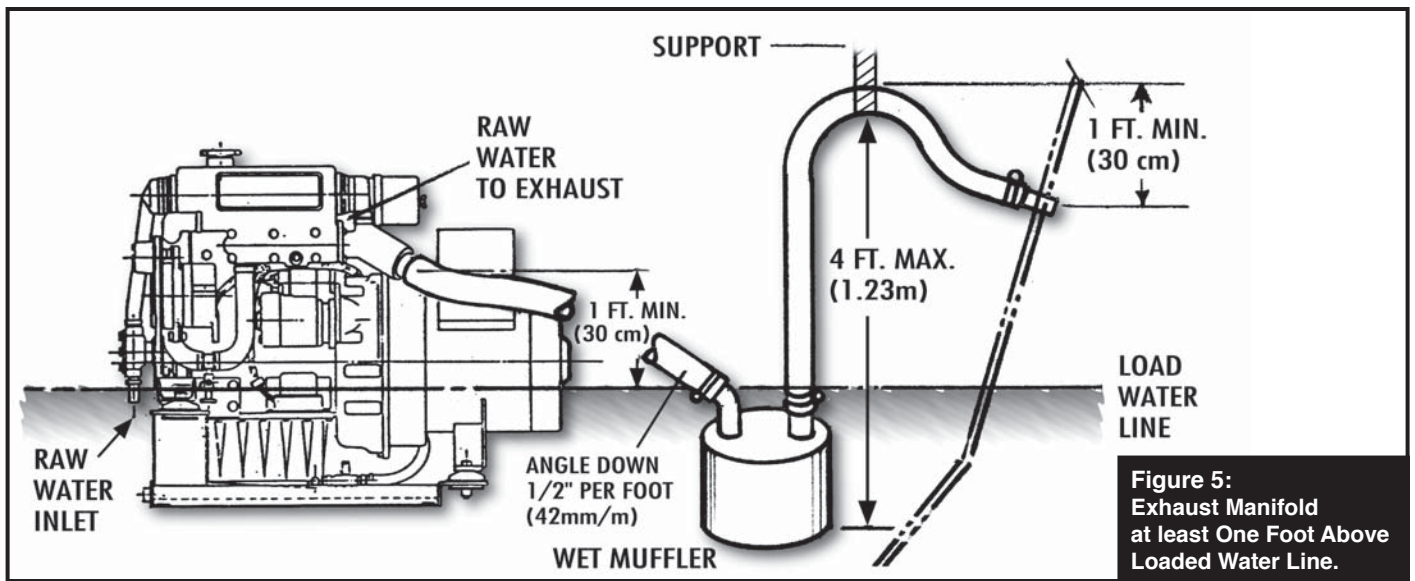

Figure 4: Siphon Break Disassembled for Cleaning.



Gen-Sep™

A Gen-Sep gas and water separator is a new and valuable tool to protect your set and quiet generator operation.

Gen-Sep will remove nearly all of the cooling water from the exhaust. That water can be drained to a hull fitting just below the waterline. This eliminates the irritating noise created by splashing and pulsating water flow at the exhaust outlet.

Several sizes of Gen-Seps are available. Follow installation instructions supplied with the unit. A basic installation diagram is shown here.

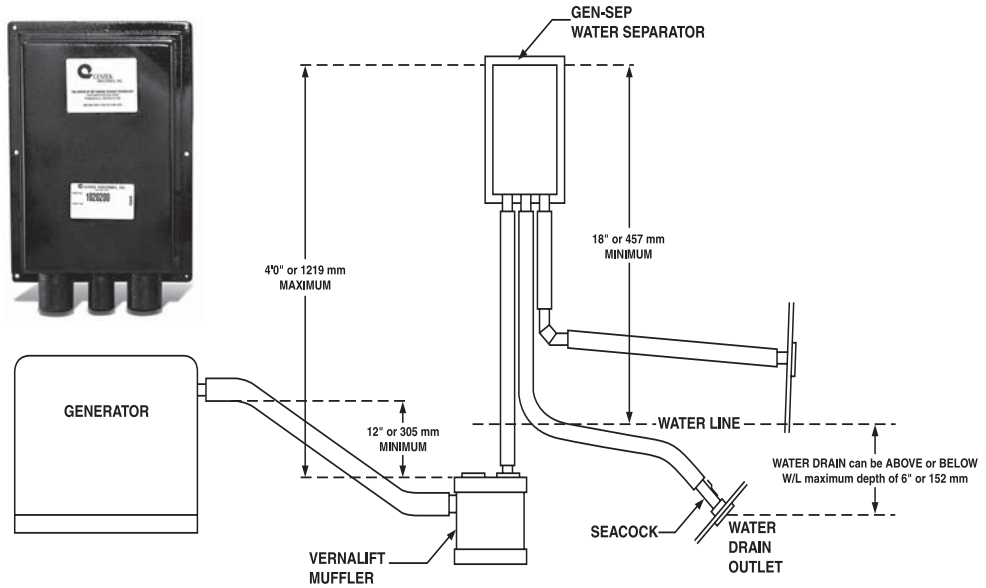

Fig. 8 Wet exhaust system with Gen-Sep installed (Courtesy Centex Industries).

Use this area to design your generator's wet exhaust system.

Northern Lights, Luggar and Technicold brands are manufactured by Alaska Diesel Electric, Inc. (ADE)



Mfg. by: **Northern Lights**
4420 14th Ave NW • Seattle, WA 98107
Tel: (206) 789-3880 • FAX (206) 782-5455
<http://www.northern-lights.com>
©2006 All rights reserved. Litho USA
L192 05/08

Dealer: